

MN-□G-13 金属ニードル・サイズ寸法一覧表

TYPE	10G	11G	12G	13G	14G	15G	16G	17G	18G	19G	20G	21G	22G	23G	24G	25G	26G	27G	28G
I.D内径[ØA]	3.00	2.60	2.20	1.90	1.60	1.40	1.26	1.07	0.86	0.67	0.60	0.50	0.40	0.33	0.31	0.26	0.21	0.16	0.15
O.D外径[ØB]	3.40	3.00	2.80	2.40	2.10	1.80	1.66	1.47	1.26	1.07	0.90	0.80	0.70	0.63	0.55	0.50	0.45	0.40	0.35
公差値	±0.03	±0.03	±0.02	±0.02	±0.02	±0.02	±0.02	±0.02	±0.02	±0.02	±0.02	±0.02	±0.02	±0.02	±0.02	±0.02	±0.02	±0.02	±0.02
(ØC)	5.25	4	4	3.5	3.5	3.5	3.5	3.5	3.5	3.5	3.5	3.5	3.5	3.5	3.5	3.5	3.5	3.5	3.5

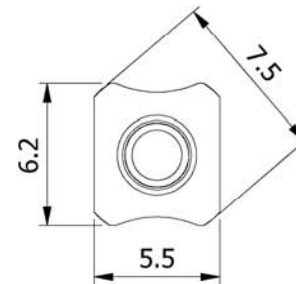
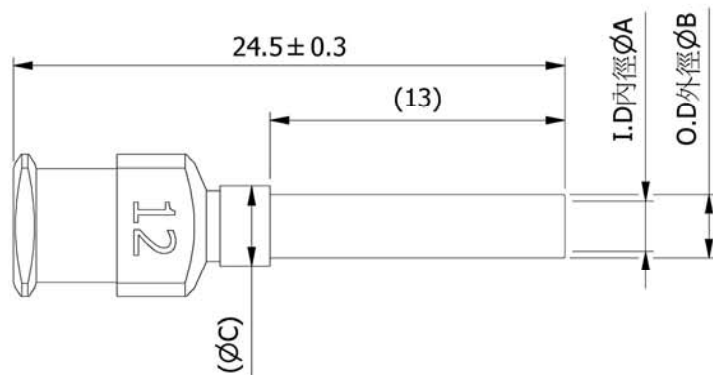
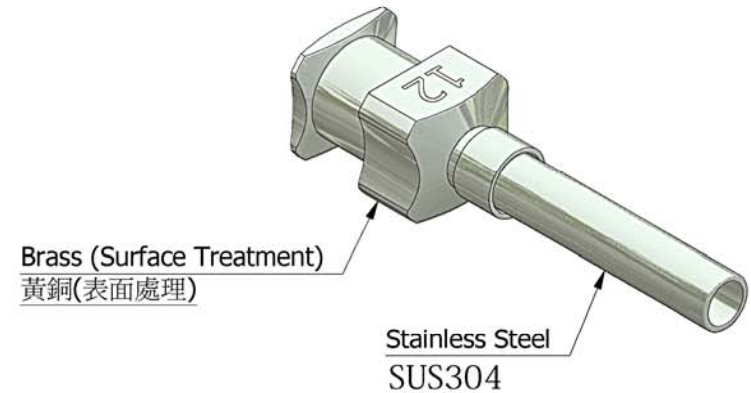
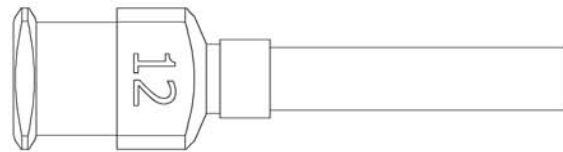

単位:mm

イーグルシステム株式会社

MN

Metal Needles
金属ニードル

MNT-□G-13 金属ニードル 2条ねじタイプ 一覧表

TYPE	10G	11G	12G	13G	14G	15G	16G	17G	18G	19G	20G	21G	22G	23G	24G	25G	26G	27G	28G
I.D内径 [ØA]	3.00	2.60	2.20	1.90	1.60	1.40	1.26	1.07	0.86	0.67	0.60	0.50	0.40	0.33	0.31	0.26	0.21	0.16	0.15
O.D外径 [ØB]	3.40	3.00	2.80	2.40	2.10	1.80	1.66	1.47	1.26	1.07	0.90	0.80	0.70	0.63	0.55	0.50	0.45	0.40	0.35
公差値	±0.03	±0.03	±0.02	±0.02	±0.02	±0.02	±0.02	±0.02	±0.02	±0.02	±0.02	±0.02	±0.02	±0.02	±0.02	±0.02	±0.02	±0.02	±0.02
(ØC)	5.25	5	3.5	3.5	3.5	3.5	3.5	3.5	3.5	3.5	3.5	3.5	3.5	3.5	3.5	3.5	3.5	3.5	3.5

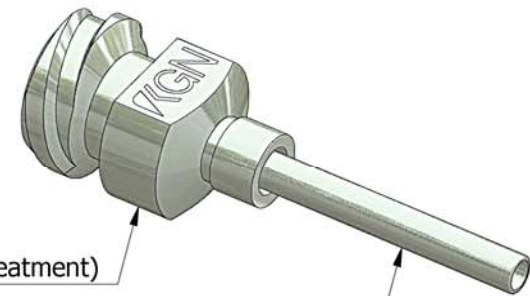
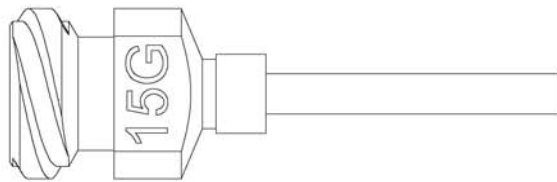

Brass (Surface Treatment)
黄銅(表面処理)

Stainless Steel
SUS304

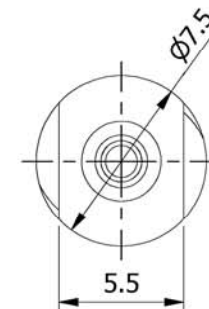
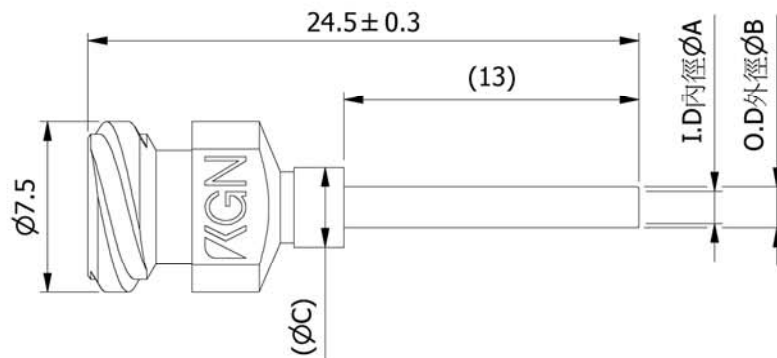

単位:mm

イーグルシステム株式会社

MNT Metal Needles Thread Type
金属ニードル 2条ねじタイプ

PND-□G-10(-UV)プラスチックニードル 2条ねじ 一覧表

TYPE	16G	17G	18G	19G	20G	21G	22G	23G	24G	25G	26G	27G	30G	32G
I.D内径[ØA]	1.26	1.07	0.86	0.67	0.60	0.50	0.40	0.33	0.31	0.26	0.21	0.20	0.15	0.10
O.D外径[ØB]	1.66	1.47	1.26	1.07	0.90	0.80	0.70	0.63	0.55	0.50	0.45	0.40	0.30	0.23
Hub Color	White	Lavender	Pink	Light brown	Light yellow	Light green	Gray	Light blue	Light red	Crocus	Orange	Light gray	Purple	Yellow

PND-32G は針長6.5mm

-UVハブカラーは黒色

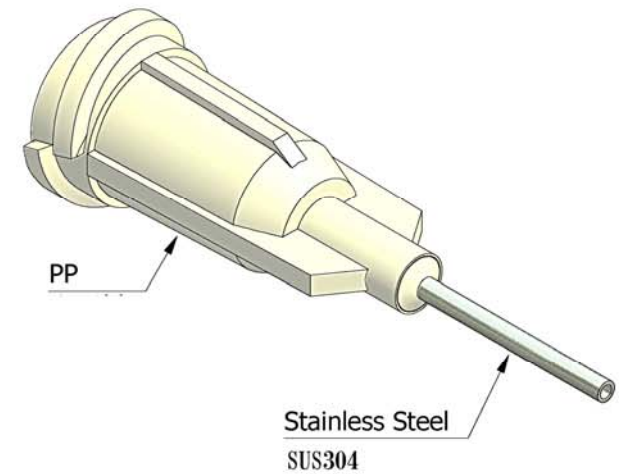
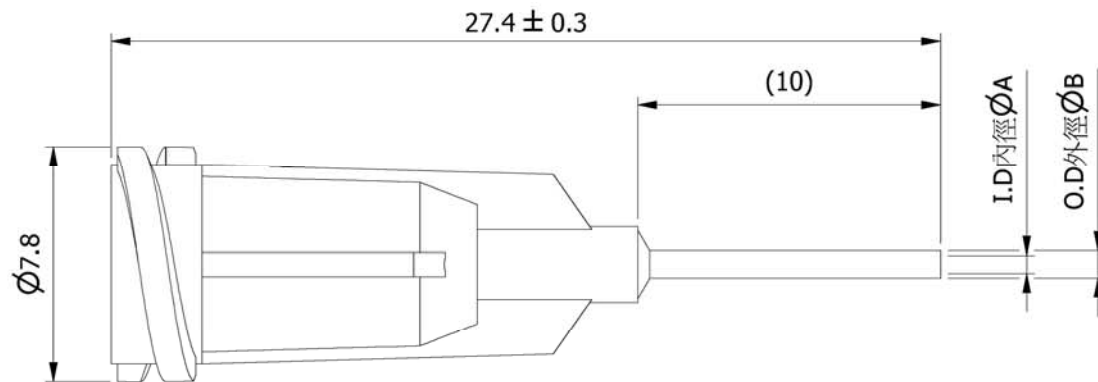

単位:mm

イーグルシステム株式会社

PND

Plastic Needles Thread Type
プラスチックニードル 2条ねじタイプ

2MN-□G-20 2本針金属系列												
TYPE	17G	18G	19G	20G	21G	22G	23G	24G	25G	26G	27G	28G
I.D 内径[ØA]	1.07	0.86	0.67	0.60	0.50	0.40	0.33	0.31	0.26	0.21	0.16	0.15
O.D 外径[ØB]	1.47	1.26	1.07	0.90	0.80	0.70	0.63	0.55	0.50	0.45	0.40	0.35

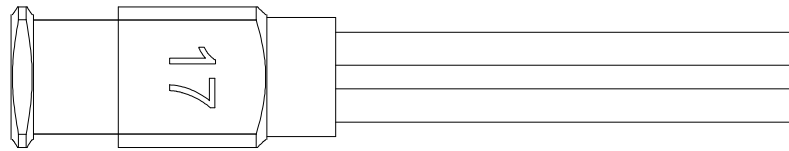

Brass (Surface Treatment)
黄銅(表面メッキ)

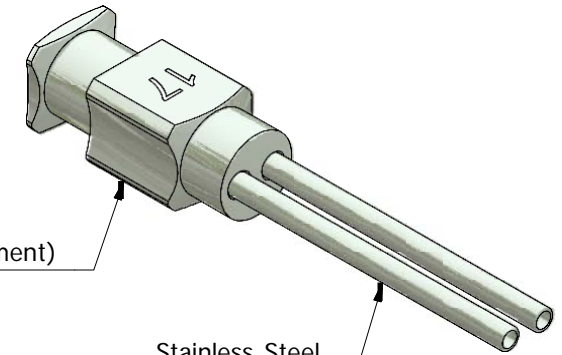

Stainless Steel
SUS304

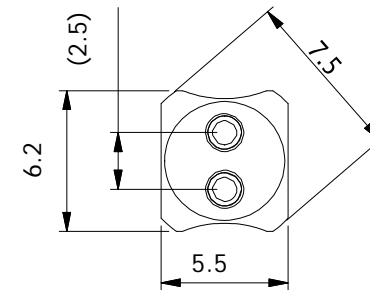
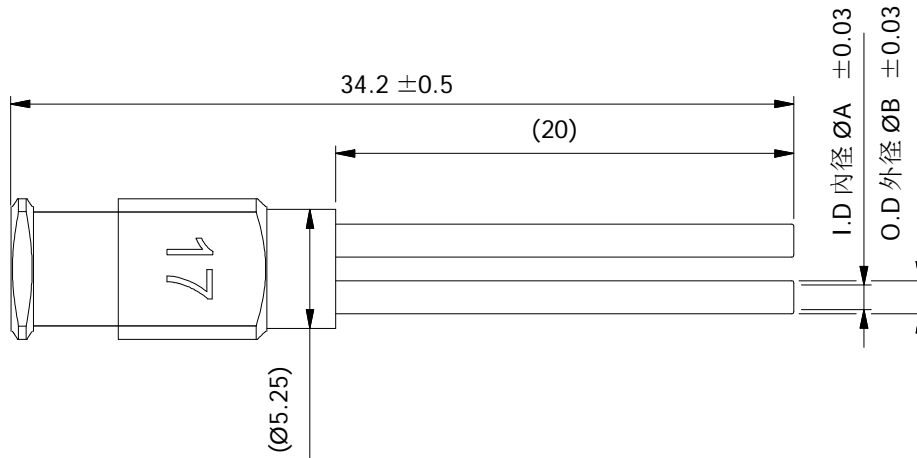

単位:mm

イーグルシステム株式会社

2MN Twin Metal Needles
2本針金属